

# Computrol C6000 Pump Control Unit

## Conduit and Wiring Overview

(Best Printed On 11x17 or Legal Paper)

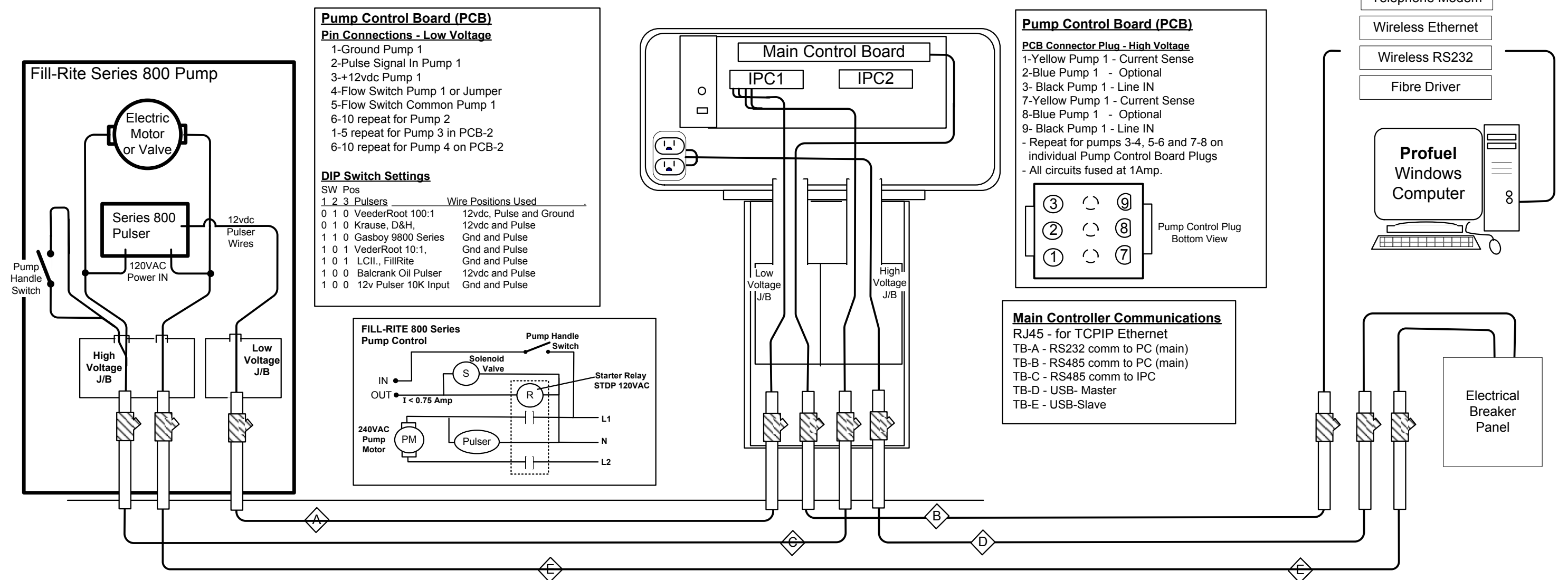

**Pump Control Board (PCB)**  
**Pin Connections - Low Voltage**  
 1-Ground Pump 1  
 2-Pulse Signal In Pump 1  
 3-+12vdc Pump 1  
 4-Flow Switch Pump 1 or Jumper  
 5-Flow Switch Common Pump 1  
 6-10 repeat for Pump 2  
 1-5 repeat for Pump 3 in PCB-2  
 6-10 repeat for Pump 4 on PCB-2

**DIP Switch Settings**

SW	Pos	1	2	3	Pulsers	Wire Positions Used
0	1	0			VeederRoot 100:1	12vdc, Pulse and Ground
0	1	0			Krause, D&H,	12vdc and Pulse
1	1	0			Gasboy 9800 Series	Gnd and Pulse
1	0	1			VeederRoot 10:1,	Gnd and Pulse
1	0	1			LCII., FillRite	Gnd and Pulse
1	0	0			Balcrank Oil Pulsar	12vdc and Pulse
1	0	0			12v Pulsar 10K Input	Gnd and Pulse

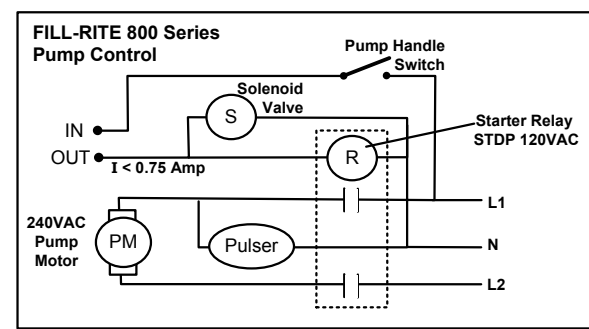

**Pump Control Board (PCB)**  
**PCB Connector Plug - High Voltage**  
 1-Yellow Pump 1 - Current Sense  
 2-Blue Pump 1 - Optional  
 3- Black Pump 1 - Line IN  
 7-Yellow Pump 1 - Current Sense  
 8-Blue Pump 1 - Optional  
 9- Black Pump 1 - Line IN  
 - Repeat for pumps 3-4, 5-6 and 7-8 on individual Pump Control Board Plugs  
 - All circuits fused at 1Amp.

**Pump Control Plug Bottom View**

**Main Controller Communications**  
 RJ45 - for TCP/IP Ethernet  
 TB-A - RS232 comm to PC (main)  
 TB-B - RS485 comm to PC (main)  
 TB-C - RS485 comm to IPC  
 TB-D - USB- Master  
 TB-E - USB-Slave

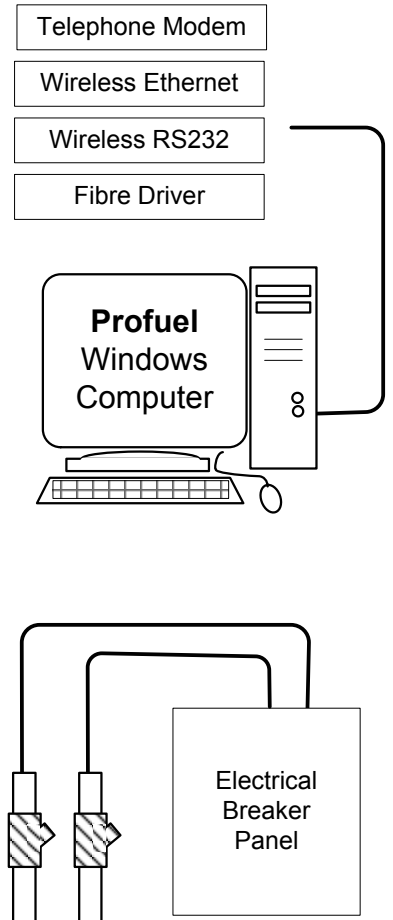

**Legend** \* Always consult Local Electrical Codes.

- 12vdc Pulsar Wire 3x18AWG stranded shielded Belden 8777
- RS232C Communication Cable 4-8, 22AWG wires, shielded, stranded
- 120VAC Pump Control Wire 12 AWG\*
- 120VAC Dedicated Circuit for Computer Power\*
- High Voltage power to pumps\*
- EYS Seals-for hazardous areas

- NOTES:**
1. Conduits shall not be sealed until approved by a Computrol technician
  2. Reset Motor shall be wired operational at all times. After the Reset Motor cycles, its internal micro-switches switch power to the 'IN' terminal point of the Computrol
  3. When external relays are used the 'OUT' terminal on the Computrol unit must directly feed the coil of a starter relay which draws less than 3/4 Amp. This is because the current sense circuit used on the Computrol Pump Control Board is fused at 1 Amp.. (The Pump Controller can sense from 0.004 Amp to max. fuse rating)
  4. In all cases a Pump Switch must be in series with the Current Sense Load. This means the user can turn the pump off and terminate the transaction.
  5. Input Power to the Computrol Unit and all LV lines shall not be run alongside the lines supplying the fuel pumps, lights or other circuits as doing so may cause intermittent computer problems due to induced voltage spikes.
  6. For communication cable lengths of greater than 200 feet it may be necessary to install line extender devices. Lightning Sponges and surge protectors may also be recommended for local applications.
  7. All wiring to be provided by Electrical Contractor. Wire terminations to be done by approved Computrol Technician.
  8. A Metal-Oxide-Varistor (MOV) should be used across all relay coils to suppress noise and spikes during switching
  9. Starter relay can be located at electrical panel, in dispenser, in pedestal, or in a separate, approved, weatherproof Hammond box. (see local restrictions for explosion proof packaging requirements.)

**computrol** FUEL SYSTEMS INC [www.computrolfuel.com](http://www.computrolfuel.com)

**C6000 Site Wiring**  
 Filename: C6000-Site-Layout-FillRite Dated: May 9<sup>th</sup>, 2006

**Computrol Security Systems Ltd.**  
 #107 - 1533 Broadway Street,  
 Port Coquitlam, British Columbia, Canada V3C 6P3  
 Tel: 604-927-1000 Fax: 604-9271004